

Procedures to file a request to the MyIPO (Intellectual Property Corporation of Malaysia) for Patent Prosecution Highway Pilot Program between the MyIPO and the KIPO (Korea Intellectual Property Office)

Part I

PPH using the national work products from the KIPO

Applicants can request accelerated examination by a prescribed procedure including submission of relevant documents on an application which is filed with the MyIPO and satisfies the following requirements under the MyIPO - KIPO PPH pilot program based on the KIPO application.

When filing a request for the PPH pilot program, an applicant must submit a request form “Request for Participation in the Patent Prosecution Highway (PPH) Pilot Program” to the MyIPO.

The PPH pilot program between MyIPO and KIPO will be in effect for three years commencing on December 1, 2020 and will end on November 30, 2023. The MyIPO and KIPO will evaluate the results of the pilot program to determine whether and how the program should be fully implemented after the trial period. The offices may terminate the PPH pilot program if the volume of participation exceeds manageable level, or for any other reason. Ex Ante notice will be published if the PPH pilot program is terminated.

1. Requirements

(a) Both the MyIPO application on which PPH is requested and the KIPO application(s) forming the basis of the PPH request shall have the same earliest date (whether this be a priority date or a filing date).

For example, the MyIPO application (including PCT national phase application) may be either:

(Case I) an application which validly claims priority under the Paris Convention from the KIPO application(s) (examples are provided in ANNEX I, Figures A, B, C, H, I and J), or

(Case II) an application which provides the basis of a valid priority claim under the Paris

Convention for the KIPO application(s) (including PCT national phase application(s)) (examples are provided in ANNEX I, Figures D and E), or

(Case III) an application which shares a common priority document with the KIPO application(s) (including PCT national phase application(s)) (examples are provided in ANNEX I, Figures F, G, L, M and N), or

(Case IV) a PCT national phase application where both the KIPO application and the MyIPO application(s) are derived from a common PCT international application having no priority claim (an example is provided in ANNEX I, Figure K).

(b) At least one corresponding application exists in the KIPO which has one or more claims that are determined to be patentable/allowable by the KIPO.

The corresponding application(s) can be the application which forms the basis of the priority claim, an application which derived from the KIPO application which forms the basis of the priority claim (e.g., a divisional application of the KIPO application or an application which claims domestic priority to the KIPO application (see Figure C in Annex I)), or an KIPO national phase application of a PCT application (see Figures H, I, J, K and L in Annex I).

Claims are “determined to be allowable/patentable” when the KIPO examiner explicitly identified the claims to be “allowable/patentable” in the latest office action, even if the application has not been granted yet.

(c) All claims on file, as originally filed or as amended, for examination under the PPH must sufficiently correspond to one or more of those claims indicated allowable in the KIPO.

Claims are considered to “sufficiently correspond” where, aside from differences due to translations and claim format, the claims in the MyIPO application are of the same or similar scope as the claims in the KIPO application, or the claims in the MyIPO are narrower in scope than the claims in the KIPO.

In this regard, a claim that is narrower in scope occurs when KIPO claim is amended to be further limited by an additional technical feature that is supported in the specification (description and/or claims).

A claim in the MyIPO which introduces a new/different category of claims to those claims indicated to be patentable/allowable in the KIPO is not considered to sufficiently correspond. For example, if the KIPO claims only contain claims to a process of manufacturing a product, then the claims in the MyIPO are not considered to sufficiently correspond if the MyIPO claims introduce product claims that are dependent on the corresponding process claims.

It is not necessary to include “all” claims determined to be patentable/allowable in the KIPO in an application in the MyIPO (the deletion of claims is allowable). For example, in the case where an application in the KIPO contains 5 claims determined to be patentable/allowable, the application in the MyIPO may contain only 3 of these 5 claims.

Any claims amended or added after the grant of the request for participation in the PPH pilot program but before the MyIPO first office action must sufficiently correspond to the claims indicated as patentable/allowable in the KIPO application.

(d) A “Request for Substantive Examination” must have been filed at the MyIPO either at the time of the PPH request or previously.

(e) The MyIPO has not begun examination of the application at the time of filing the PPH request.

2. Documents to be submitted

Documents (a) to (d) below must be submitted by attaching to the PPH request.

(a) Copies of all office actions (which are relevant to substantial examination for patentability in the KIPO) which were issued for the corresponding application by the KIPO, and translations thereof¹.

¹ Machine translations will be admissible, but if it is impossible for the examiner to understand the outline of the translated office action or claims due to insufficient translation, the examiner can

Either Bahasa Malay or English is acceptable as translation language. The applicant does not have to submit a copy of KIPO office actions and translations of them when those documents are provided via KIPRIS (KIPO's dossier access system) because the office actions and their machine translations are available for the MyIPO examiner via the KIPRIS. If they cannot be obtained by the MyIPO examiner via the KIPRIS, the applicant may be notified and requested to provide the necessary documents.

(b) Copies of all claims determined to be patentable/allowable by the KIPO, and translations thereof.

Either Bahasa Malay or English is acceptable as translation language. The applicant does not have to submit a copy of claims indicated to be patentable/allowable in the KIPO, and translations thereof when the documents are provided via KIPRIS (KIPO's dossier access system) because they are available for the MyIPO examiner via the KIPRIS. If they cannot be obtained by the MyIPO examiner via the KIPRIS, the applicant may be notified and requested to provide the necessary documents.

(c) Copies of references cited by the KIPO examiner

If the references are patent documents, the applicant does not have to submit them. When the MyIPO does not possess the patent document, the applicant has to submit the patent document at the examiner's request. Non-patent literature must always be submitted. The translations of the references are unnecessary.

(d) Claim correspondence table

The applicant requesting PPH must submit a claim correspondence table, which indicates how all claims in the MyIPO application sufficiently correspond to the patentable/allowable claims in the KIPO application.

When claims are just literal translation, the applicant can just write down that “they are the same” in the table. When claims are not just literal translation, it is necessary to explain the sufficient correspondence of each claim.

When the applicant has already submitted above documents (a) to (d) to the MyIPO through simultaneous or past procedures, the applicant may incorporate the documents by reference and does not have to attach them.

Part II

PPH using the PCT international work products from the KIPO

Applicants can request accelerated examination by a prescribed procedure including submission of relevant documents on an application which is filed with the MyIPO and satisfies the following requirements under the MyIPO-KIPO Patent Prosecution Highway pilot program based on PCT international work products(PCT-PPH pilot program).

When filing a request for the PCT-PPH pilot program, an applicant must submit a request form to the MyIPO.

The Offices may terminate the PCT-PPH pilot program if the volume of participation exceeds manageable level, or for any other reason. Ex Ante notice will be published if the PPH pilot program is terminated.

1. Requirements

The application which is filed with the MyIPO and on which the applicant files a request under the PCT-PPH must satisfy the following requirements:

(1) The latest work product in the international phase of a PCT application corresponding to the application (“international work product”), namely the Written Opinion of International Search Authority (WO/ISA), the Written Opinion of International Preliminary Examination Authority (WO/IPEA) or the International Preliminary Examination Report (IPER), indicates at least one claim as

patentable/allowable (from the aspect of novelty, inventive steps and industrial applicability).

Note that the ISA and the IPEA which produced the WO/ISA, WO/IPEA and the IPER are limited to the KIPO, but, if priority is claimed, the priority claim can be to an application in any Office, see example A' in ANNEX II (application ZZ can be any national application). The applicant cannot file a request under PCT-PPH on the basis of an International Search Report (ISR) only.

In case any observation is described in Box VIII of WO/ISA, WO/IPEA or IPER which forms the basis of a PCT-PPH request, the applicant must explain why the claim(s) is/are not subject to the observation irrespective of whether or not an amendment is submitted to correct the observation noted in Box VIII. The application will not be eligible for participating in PCT-PPH pilot program if the applicant does not explain why the claim(s) is/are not subject to the observation. In this regard, however, it does not affect the decision on the eligibility of the application whether the explanation is adequate and/or whether the amendment submitted over comes the observation noted in Box VIII.

(2) The relationship between the application and the corresponding international application satisfies one of the following requirements:

(A) The application is a national phase application of the corresponding international application. (See Figures A, A', and A'' in ANNEX II)

(B) The application is a national application as a basis of the priority claim of the corresponding international application. (See Figure B in ANNEX II)

(C) The application is a national phase application of an international application claiming priority from the corresponding international application. (See Figure C in ANNEX II)

(D) The application is a national application claiming foreign priority from the corresponding international application. (See Figure D in ANNEX II)

(E) The application is the derivative application (divisional application and application claiming domestic priority etc.) of the application which satisfies one of the above requirements (A) – (D). (See Figures E1 and E2 in ANNEX II).

(3) All claims on file, as originally filed or as amended, for examination under the PCT-PPH must sufficiently correspond to one or more of those claims indicated as allowable in the latest international work product of the corresponding international application.

Claims are considered to "sufficiently correspond" where, accounting for differences due to translations and claim format, the claims in the MyIPO are of the same or similar scope as the claims indicated as allowable in the latest international work product, or the claims in the MyIPO are narrower in scope than the claims indicated as allowable in the latest international work product.

In this regard, a claim that is narrower in scope occurs when a claim indicated as allowable in the latest international work product is amended to be further limited by an additional feature that is supported in the specification (description and/or claims).

A claim in the MyIPO which introduces a new/different category of claims to those claims indicated as allowable in the latest international work product is not considered to sufficiently correspond. For example, where the claims indicated as allowable in the latest international work product only contain claims to a process of manufacturing a product, then the claims in the MyIPO are not considered to sufficiently correspond if the MyIPO claims introduce product claims that are dependent on the corresponding process claims. Any claims amended or added after the grant of the request for participation in the PCT-PPH pilot program need not to sufficiently correspond to the claims indicated as allowable in the latest international work product.

(4) The MyIPO has not begun examination of the application at the time of request for the PCT- PPH.

(5) A "Request for Substantive Examination" in the ordinary route must have been filed at the MyIPO either at the time of the PCT- PPH request or previously.

2. Documents to be submitted

The applicant must submit the following documents attached to the request form in filing a request under PCT-PPH. Some of the documents may not be required to submit in certain cases.

(1) A copy of the latest international work product which indicated the claims to be patentable/allowable and their Bahasa Malay or English translations if they are not in English.

In case the application satisfies the relationship 1. (2)(A), the applicant need not submit a copy of the International Preliminary Report on Patentability (IPRP) and any English translations thereof because a copy of these documents is already contained in the file-wrapper of the application. In addition, if the copy of the latest international work product and the copy of the translation are available via “PATENTSCOPE (registered trademark)”², an applicant need not submit these documents, unless otherwise requested by the MyIPO.

(WO/ISA and IPER are usually available as “IPRP Chapter I” and “IPRP Chapter II” respectively in 30 months after the priority date.)

(2) A copy of a set of claims which the latest international work product of the corresponding international application indicated to be patentable/allowable and their Bahasa Malay or English translations if they are not in English.

If the copy of the set of claims which are indicated to be patentable/allowable is available via “PATENTSCOPE (registered trademark)” (e.g. the international Patent Gazette has been published), an applicant need not submit this document unless otherwise requested by the MyIPO. Where the set of claims is written in Korean, the translations thereof must be still submitted by an applicant.

(3) A copy of references cited in the latest international work product of the international application corresponding to the application.

² <http://www.wipo.int/pctdb/en/index.jsp>

If the reference is a patent document, the applicant is not required to submit it. In case the MyIPO has difficulty in obtaining the document, however, the applicant may be asked to submit it. Non-patent literature must always be submitted. Translations of cited references are unnecessary.

(4) A claims correspondence table which indicates how all claims in the application sufficiently correspond to the claims indicated to be patentable/allowable.

When claims are just literal translation, the applicant can just write down that “they are the same” in the table. When claims are not just literal translation, it is necessary to explain the sufficient correspondence of each claim based on the criteria 1. (3) (Please refer to the Example form below).

When an applicant has already submitted the above mentioned documents (1) - (4) to the MyIPO through simultaneous or past procedures, the applicant may incorporate the documents by reference and is thus not required to attach the documents.



Intellectual Property Corporation of Malaysia

**Request for participation in the
Patent Prosecution Highway (PPH) Pilot Programme**

A. Application Data

Application Number	:	_____
Filing Date	:	_____
Applicant	:	_____
Title of Invention	:	_____

B. Request

The applicant requests participation in the Patent Prosecution Highway (PPH) pilot program based on:

Office of Earlier Examination (OEE)	:	_____
OEE Application Number (National or PCT application number)	:	_____
OEE Work Products Type	:	
<input type="checkbox"/>	National/Regional Office Action(s)	
<input type="checkbox"/>	International Authority Action(s) (ISA, IPEA or IPER)	
OEE application filing/priority date	:	_____

C. Required documents

The following documents are attached:

1. A copy of OEE work products;
 Translation of the documents in English or Bahasa Malaysia; or
 The office is requested to retrieve these documents via the Dossier Access System or PATENTSCOPE or AIPN (list to be provided)
2. Copies of all claims determined to be patentable/allowable by OEE;
 Translations of the documents in English or Bahasa Malaysia; or
 The office is requested to retrieve these documents via the Dossier Access System or PATENTSCOPE or AIPN (list to be provided)
3. A copy of non-patent documents cited in OEE work products;
 Translations of the documents in English or Bahasa Malaysia.
4. Claim Correspondence Table.
5. If any of the above mentioned documents have been submitted before, please specify application number and date of submission.

Application number : _____

Date of submission : _____

D. Name and Signature of applicant or agent:

Name and signature:	Date:

Claim Correspondence Table

The claim in the MyIPO application	The patentable claim in the OEE application	Remarks about the correspondence

A

A case meeting requirement (a) (I) - Paris route -

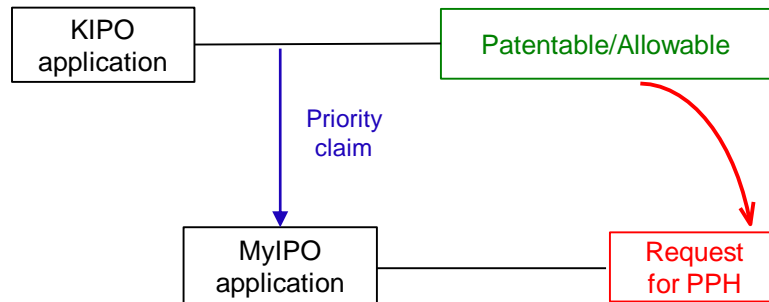

OK

B

A case meeting requirement (a) (I) - PCT route -

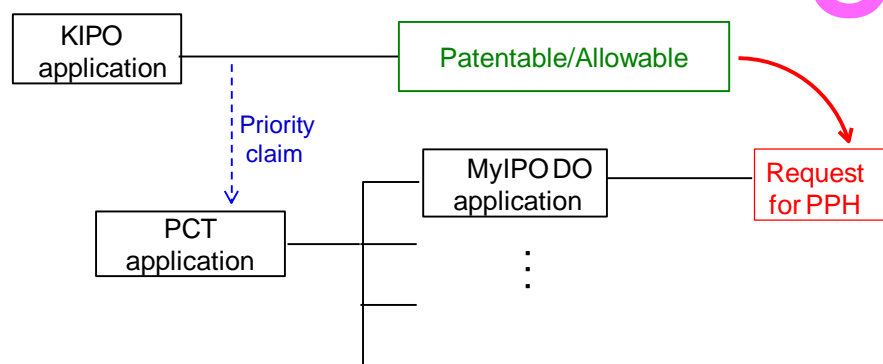

OK

DO: Designated Office

C

A case meeting requirement (a) (I)
- PCT route, Domestic Priority -

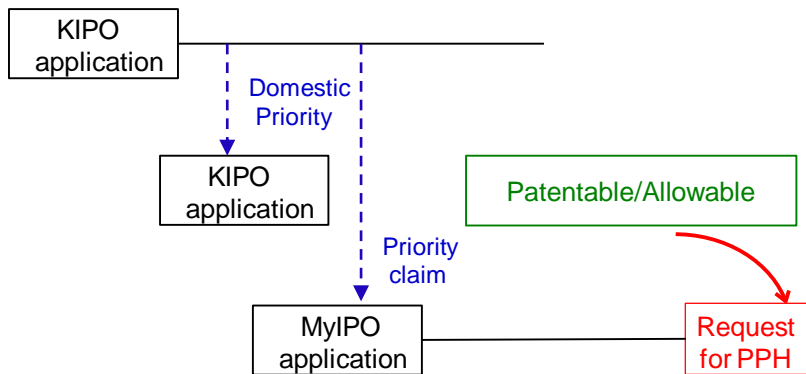

OK

D

A case meeting requirement (a) (II)
- Paris route -

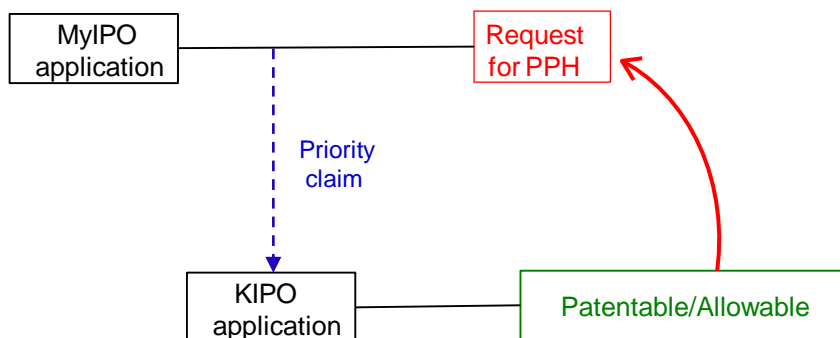

OK

E A case meeting requirement (a) (II)
- PCT route -

OK

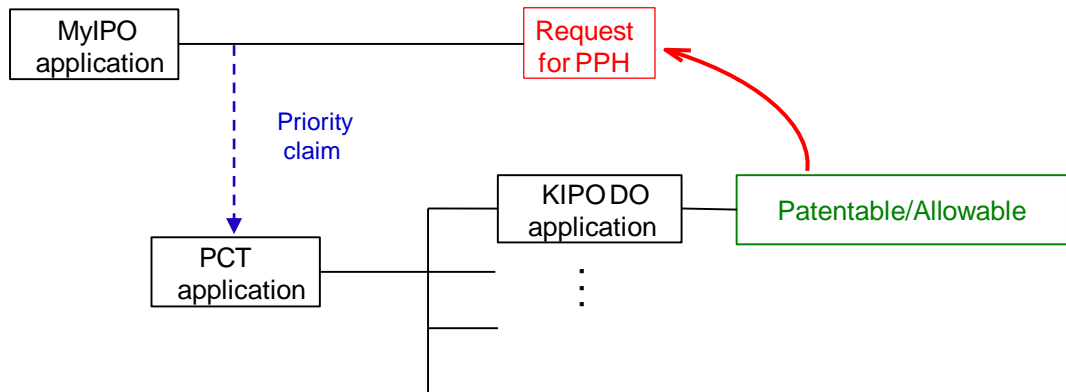

F A case meeting requirement (a) (III)
- Paris route, but the first application is from the third country -

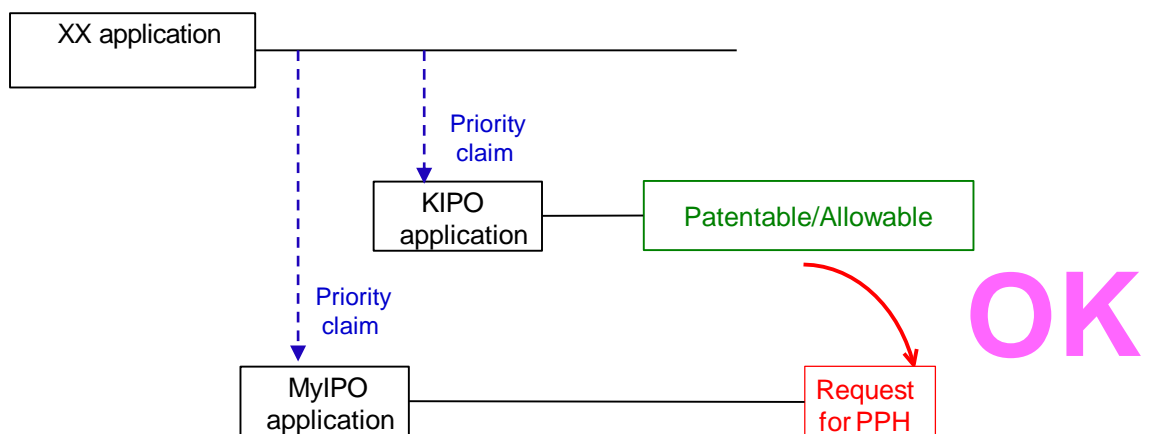

XX : the office other than the KIPO

G A case meeting requirement (a) (III)

- PCT route, but the first application is from the third country -

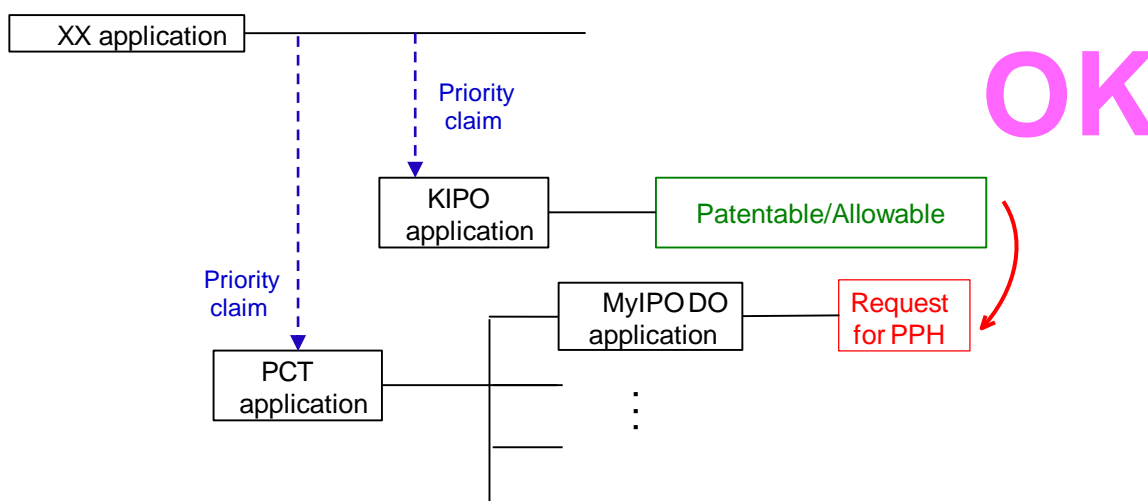

XX : the office other than the KIPO

H A case meeting requirement (a) (I)

- Paris route & Complex priority -

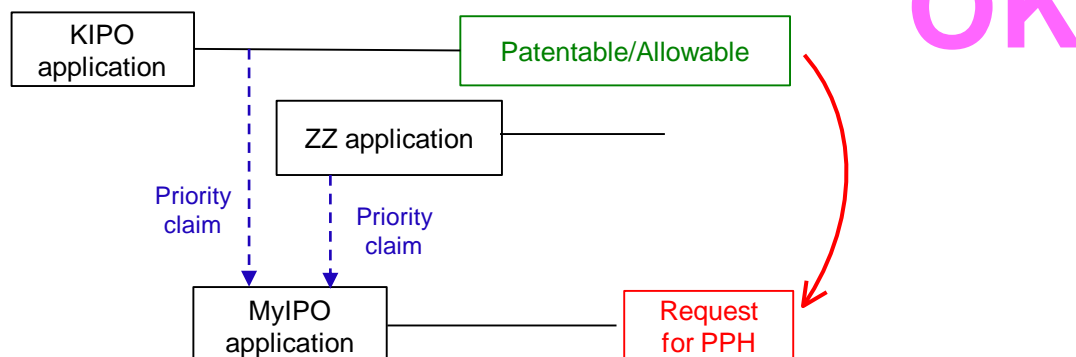

ZZ : any office

I

A case meeting requirement (a) (I)

- Paris route & divisional application -

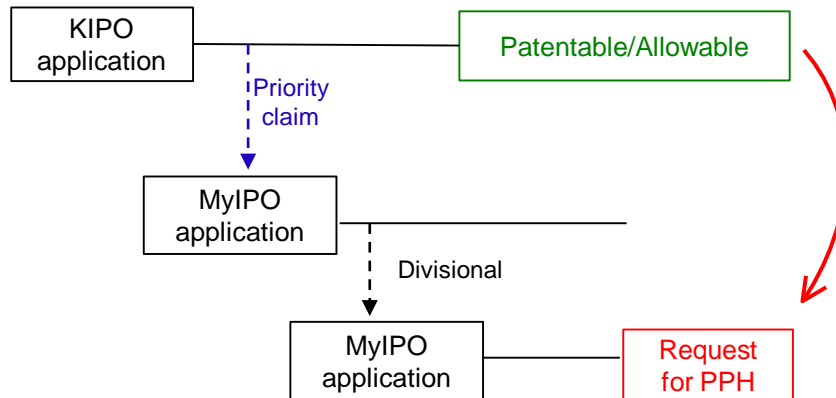

OK

J

A case meeting requirement (a) (I)

- PCT route -

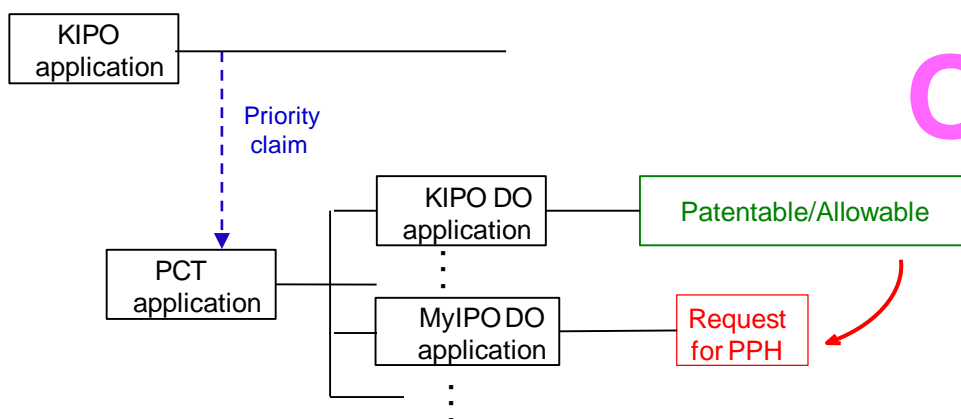

OK

K

A case meeting requirement (a) (IV)

- Direct PCT route -

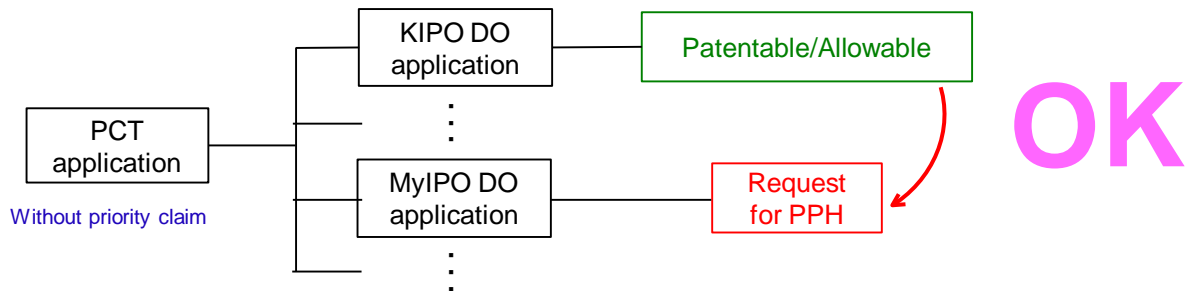

L

A case meeting requirement (a) (III)

- Direct PCT & Paris route -

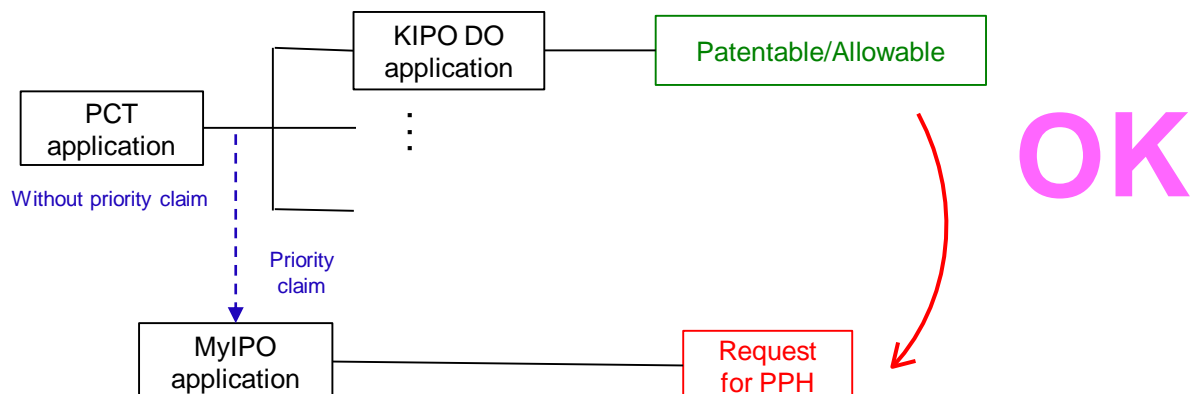

M

A case meeting requirement (a) (III)

- Direct PCT & PCT route -

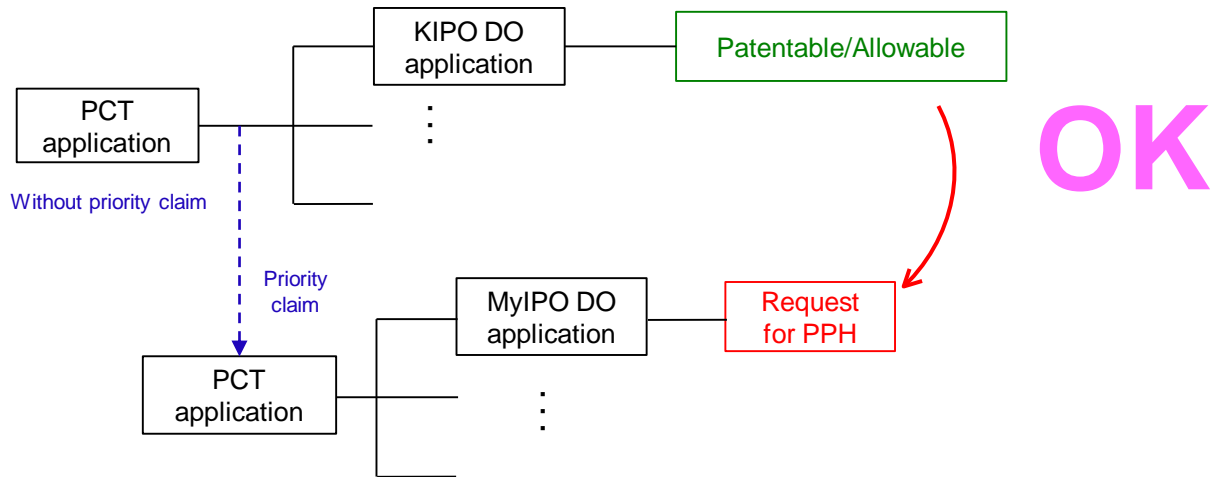

N

A case meeting requirement (a) (III)

- Direct PCT & PCT route -

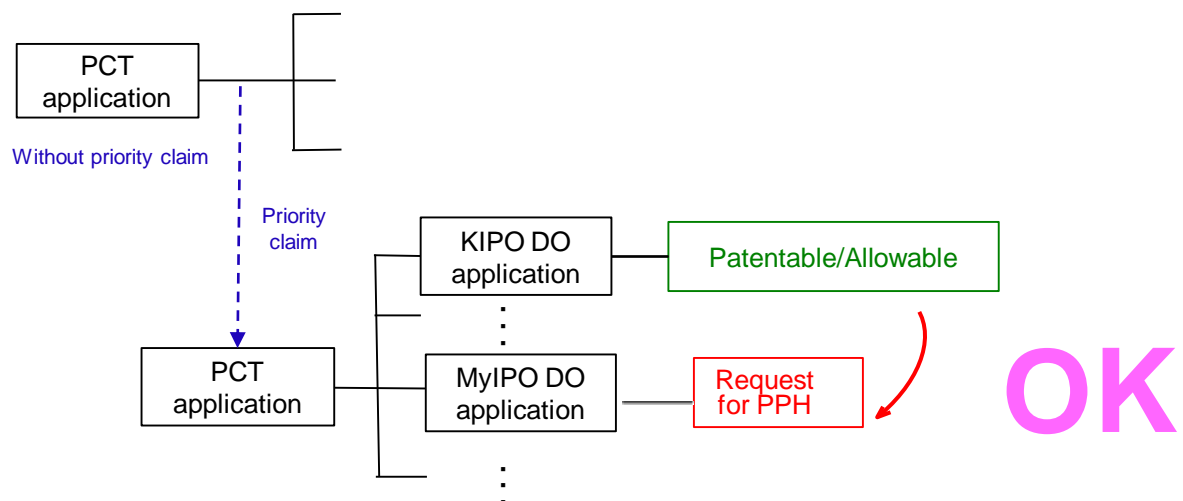

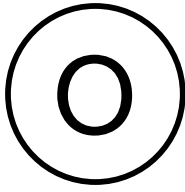

A case not meeting requirement (d)

- Examination has begun before a request for PPH -

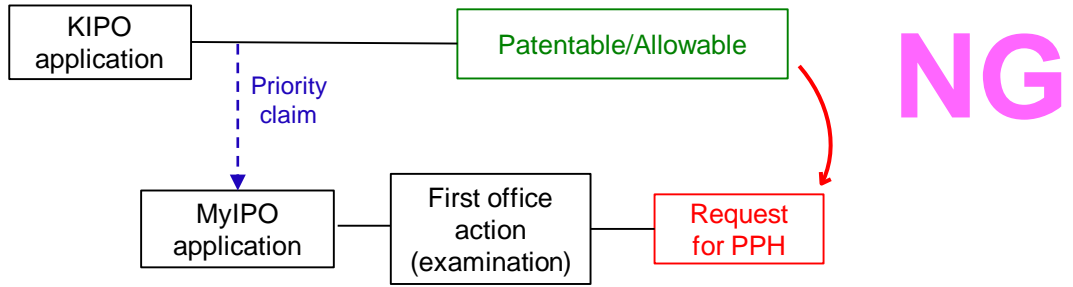

(A) The application is a national phase application of the corresponding international application.

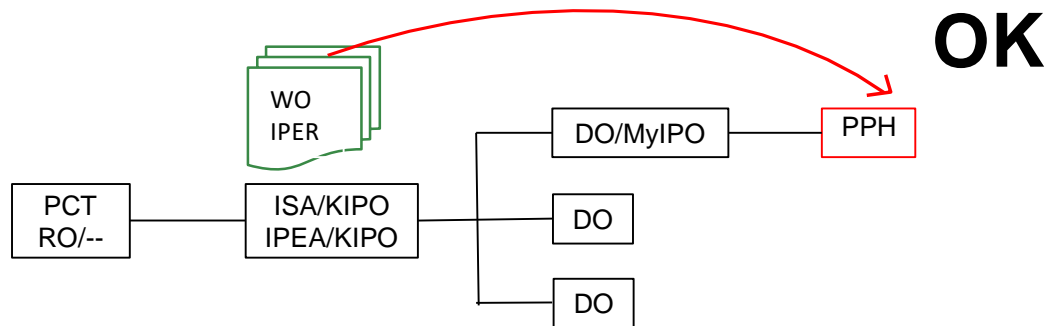

**(A') The application is a national phase application of the corresponding international application.
(The corresponding international application claims priority from a national application.)**

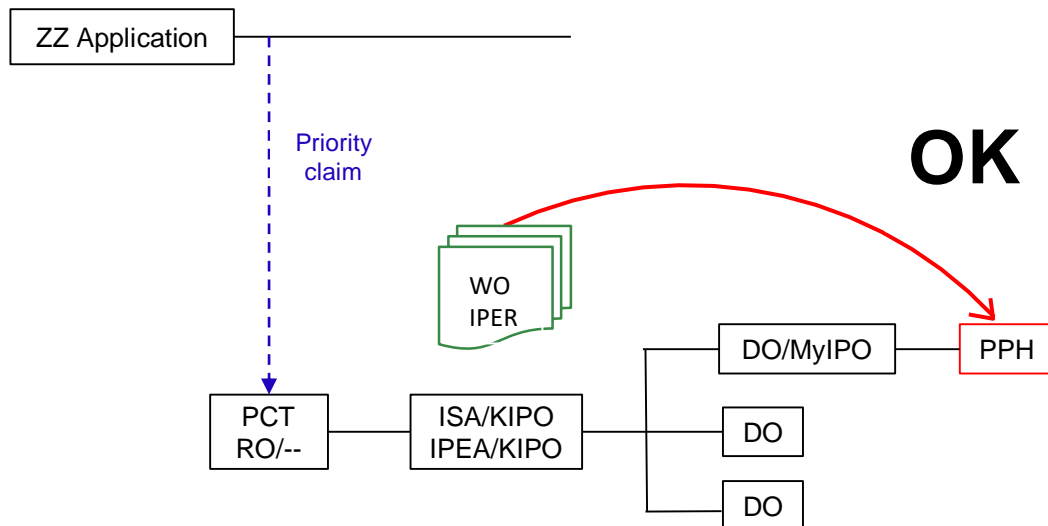

ZZ : any office

(A'') The application is a national phase application of the corresponding international application. (The corresponding international application claims priority from an international application.)

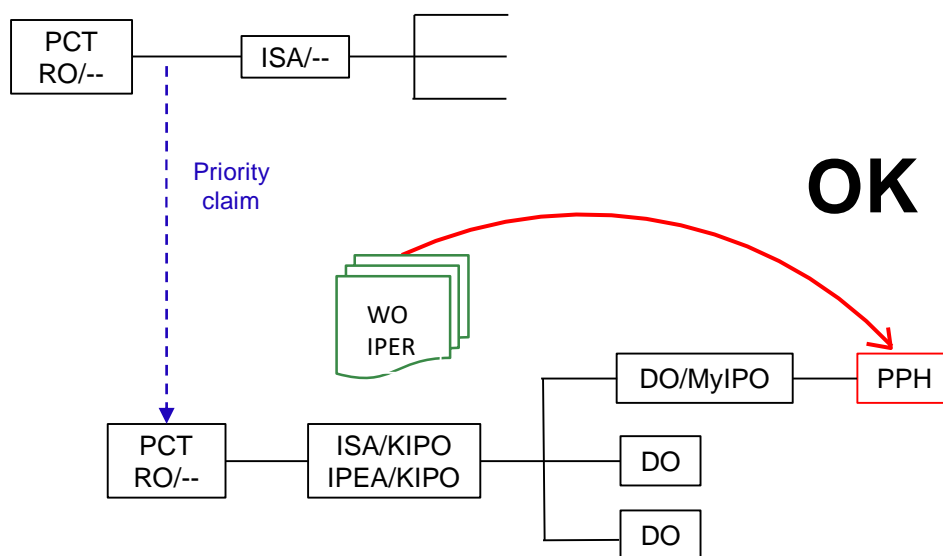

(B) The application is a national application as a basis of the priority claim of the corresponding international application.

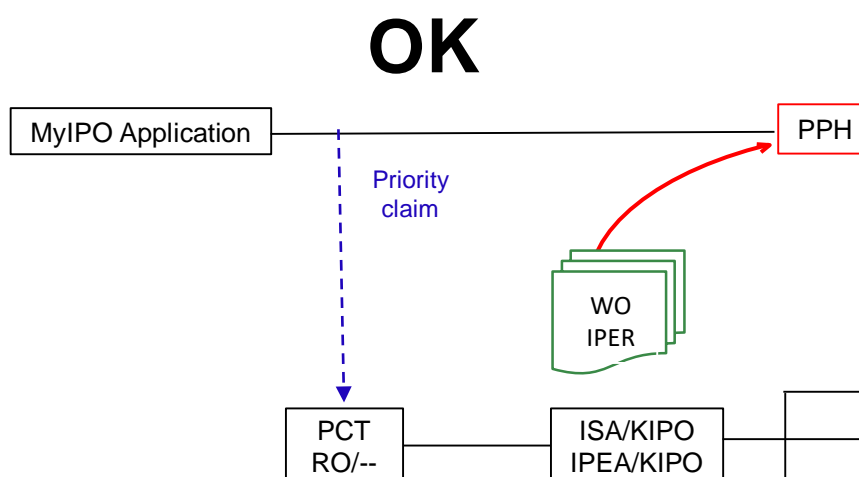

(C) The application is a national phase application of an international application claiming priority from the corresponding international application.

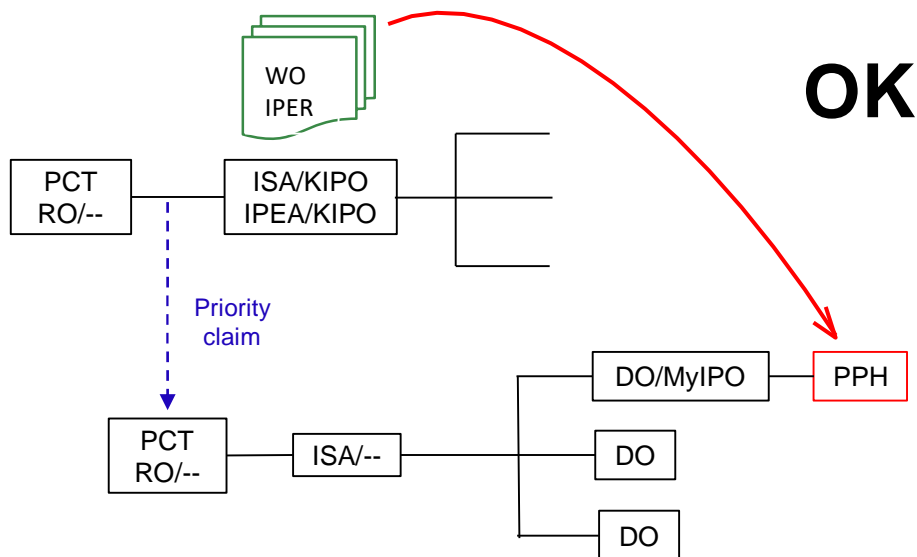

(D) The application is a national application claiming foreign/domestic priority from the corresponding international application.

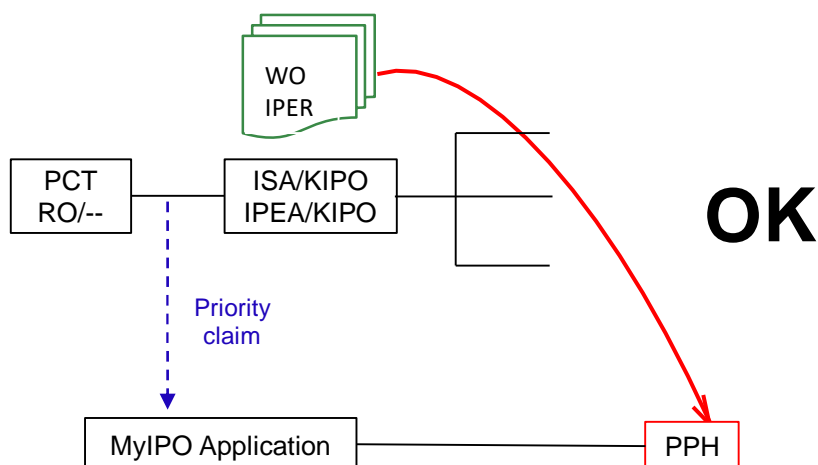

(E1) The application is a divisional application of an application which satisfies the requirement (A).

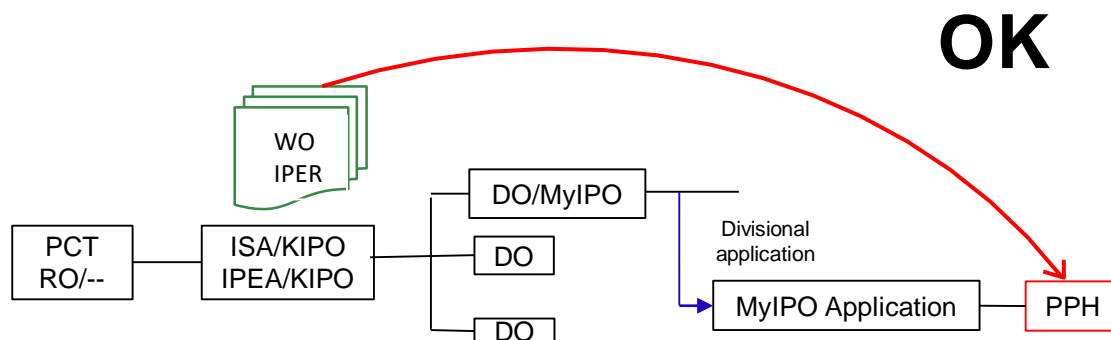

(E2) The application is an application claiming domestic priority from an application which satisfies the requirement (B).

