

A PACKAGE FOR DISPLAYING AND DISPENSING ITEMS

Technical Field

5 The present invention relates generally to a package for displaying and dispensing items.

Background Art

One of the prior arts disclosed a standard form of packaging is a discrete packet
10 containing ten individual sachets of tea. Those packets are normally packed into a box
container having a removable front wall, or sometimes a portion of the top wall. When
such container is placed on the shelf, with the front wall thereof removed, customers may
avail themselves of the packets, as the container is placed directly on the shelf in its 'open
state'. However, after the foremost packets have been removed, it becomes increasingly
15 difficult to remove remaining packets from the container, especially the rearmost rows.

Summary of the Invention

The present invention has been made in consideration of the aforementioned background.
20 According to the present invention, there is provided a package for displaying and
dispensing items comprising a container having an openable front portion, a series of
items in a row within the container, a pull member accessible at the front portion when
the container is opened whereby pulling the pull member supply a force to the items in
the row farthest from the front portion for all the items in the row to move forward
25 simultaneously to display the next item at the front portion.

In an embodiment of the invention, the pull member comprises an elongate strip where
one end of the elongate strip protruding beyond the front item in the row when the
container is opened while the other end of said elongate strip having a panel contacting
30 the rearmost item in the row. Preferably, the pull member is made of a single cardboard
blank.

In an embodiment of the invention, the elongate strip is divided into discrete portions by perforated lines thereon to enable protruding parts of the elongate strip to be removed as the protruding parts are revealed by pulling of the items in the row.

- 5 In an embodiment of the invention, the package comprises of at least two rows of items, whereby the pull member is packaged into the container with the elongate strip located between the two rows of items and the end portion located behind the rearmost two items.

In an embodiment of the invention, the item in the rows are packets of tea sachets or
10 other packets packed into a container.

Brief Description of the Drawings

Embodiments of the invention will now be described, by way of example only, by
15 reference to the accompanying drawings in which :

Figure 1 shows a perspective view of one embodiment of a package prior to opening of a front portion.

- 20 Figure 2 shows a plan view of a single blank cut of a pull member.

Figure 3 shows a perspective view of Figure 2 in the formed of a pull member to be packaged within the items in the package as shown in Figure 1.

- 25 Figure 4 shows a perspective view of the package shown in Figure 1, with a front portion thereof being removed to open the package and with the pull member being arranged between two rows of the items for convenient removal.

Figure 5 shows a cut-away view of the package shown in Figure 4 to illustrate its
30 contents when one of the items is removed.

Detail Description of the Preferred Embodiment

Referring to figure 1, a package (10) is shown in the form of normal display package and is made from thin cardboard. The package (10) is of a rectangular configuration to accommodate the items (not shown) such as packets of tea sachets or other packets which have similar size and being arranged in series to form rows. The package (10) contains a container (12) with a perforated line (14) such that it indicates a section of a package (10) that may be removed.

Figure 2 shows a single blank for a manually operable pull element (18) to be packaged with the items into a container (12). The single blank comprises an elongate strip (20) extending from a panel (22) that includes a centrally located slit (24). A first fold line (26) is located across the elongate strip (20) where it joins the panel (22) and a second fold line (28) is located along the elongate strip (20) a distance equal to the distance to the slit (24) in the opposite direction. Beyond the second fold line (28), the elongate strip (20) is preferably divided into discrete portions by perforated lines (30).

By referring to figure 3, the blank is formed into a pull element (18) by folding along the first fold line (26) such that the elongate strip (20) overlies the panel (22) and inserting the end of the elongate strip (20) through the slit (24), bending the strip (20) at the second fold line (28) and pulling the strip (20) through the slit (24) for it to extend outwardly from the panel (22) and generally perpendicular thereto.

As shown in Figure 4, when the front portion (16) of the container (12) is removed by peeling along the perforated line (14), the end of the outermost layers of the packets (32) in the rows will be exposed. The pull member (18) is packaged into a container (12) with the elongate strip (20) located between the two rows of the packets (32) and the panel (not shown) located behind the rearmost two packets (not shown). The free end of the elongate strip (20) of the pull member (18) will be exposed and protruded a short distance beyond the front faces of those two front packets (32).

As being shown in Figure 5, during the operation, when the front portion (16) is removed, the first user will simply withdraw a first packet (34) from either row. The first packet (34) on each row is placed in the region of the perforated line (16) can be taken easily by the user without any obstruction and difficulties.

5

If a next packet (36) in either row is to be removed, the free end of the elongate strip (20) is of sufficient length to be conveniently grasped between user's forefinger and thumb. The user will merely grasp the end (20) and pull it outwardly. Therefore, a continued of the elongate strip (20) which is attached to the panel (22) behind the rearmost two
10 packets (36) will cause all the packets (36) in a row to move forward so that the next packet (36) arrives in the region of the perforated line. Then, the outermost packet (36) can likewise be conveniently accessible and easily removed by the user from the container (12). The excessive length of the protruding end of the elongate strip (20) may advantageously then be removed by tearing along the perforated line (30) and will remain
15 a sufficient length to be grasped by a next user. Accordingly, a substantially thin material such as cardboard may be employed as the pull member (18) without danger of tearing during the operation.

While particular example of the present invention has been shown and described, it is
20 apparent that changes and modifications maybe made therein without departing from the invention in its broadest aspects. The aim of the appended claims, therefore, is to cover all such changes and modifications as fall within the scope of the invention.

25

Claim

1. A package (10) for displaying and dispensing items (32) comprising,
a container (12) having an openable front portion (16);
5 a series of items (32) in a row within the container (12);
a pull member (18) accessible at the front portion (16) when the container (12) is
opened;
whereby pulling the pull member (18) supply a force to the item (32) in the row
farthest from the front portion (16) for all the item (32) in the row to move
10 forward simultaneously to display the next item (32) at the front portion (16).
2. The package (10) according to claim 1, wherein the pull member (18) comprises
an elongate strip (20), one end of the elongate strip (20) protruding beyond the
front item (32) in the row when the container (12) is opened, and the other end of
15 said elongate strip (20) having a panel (22) contacting the rearmost item (32) in
the row.
3. The package (10) according to claim 2, wherein the elongate strip (20) is divided
into discrete portions by perforated lines (30) thereon to enable protruding parts of
20 the elongate strip (20) to be removed as the protruding parts are revealed by
pulling of the items (32) in the row.
4. The package (10) according to any one of the preceding claims, comprising of at
least two rows of items (32), whereby the pull member (18) is packaged into the
25 container (12) with the elongate strip (20) located between the two rows of items
(32) and the end portion (22) located behind the rearmost two items.
5. The package (10) according to claim 1, wherein the pull member (18) is made of a
single cardboard blank.

6. The package (10) according to any one of the preceding claims, wherein the item (32) in the rows are packets of tea sachets or other packets packed into a container (12).

ABSTRACT**A PACKAGE FOR DISPLAYING AND DISPENSING ITEMS**

5 The present invention relates generally to a package for displaying and dispensing items. A known form of packaging is normally placing items into a container having a removable front wall, or a removable portion of a top wall. When the container is placed on the shelf in its 'open state', consumers may easily avail themselves of the items. However, after the foremost items have been removed, it becomes difficult to remove the rear items easily. The present invention discloses a package (10) for displaying and
10 dispensing items (32) in a row comprising a container (12) with an openable front portion. A pull member (18) is accessible at the front portion (16) when the container (12) is opened. During the operation, by pulling the pull member (18) will cause the items (32) in the row to move forward for removal by the user.

15

(Figure 5)

20

FIG 1

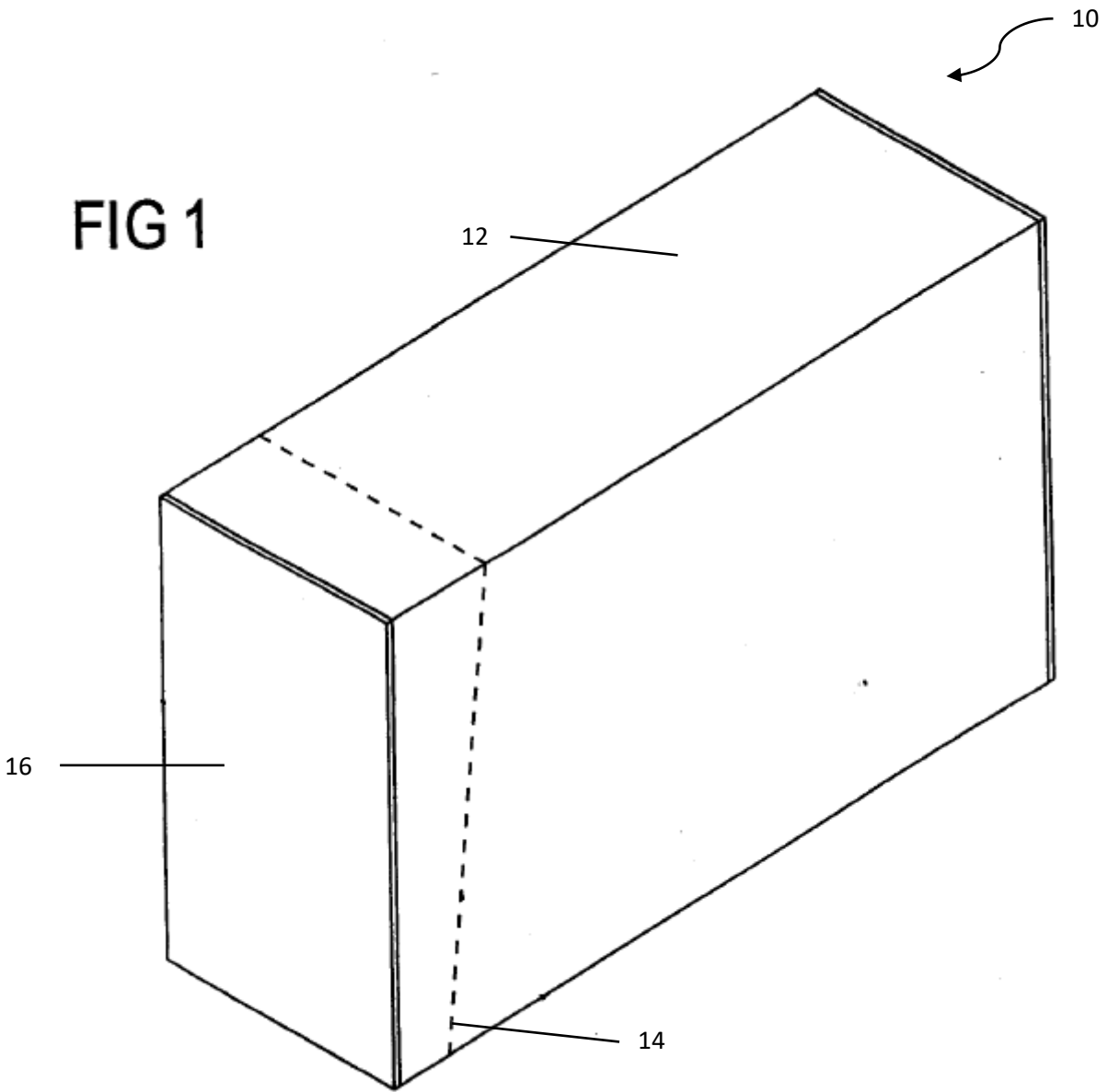

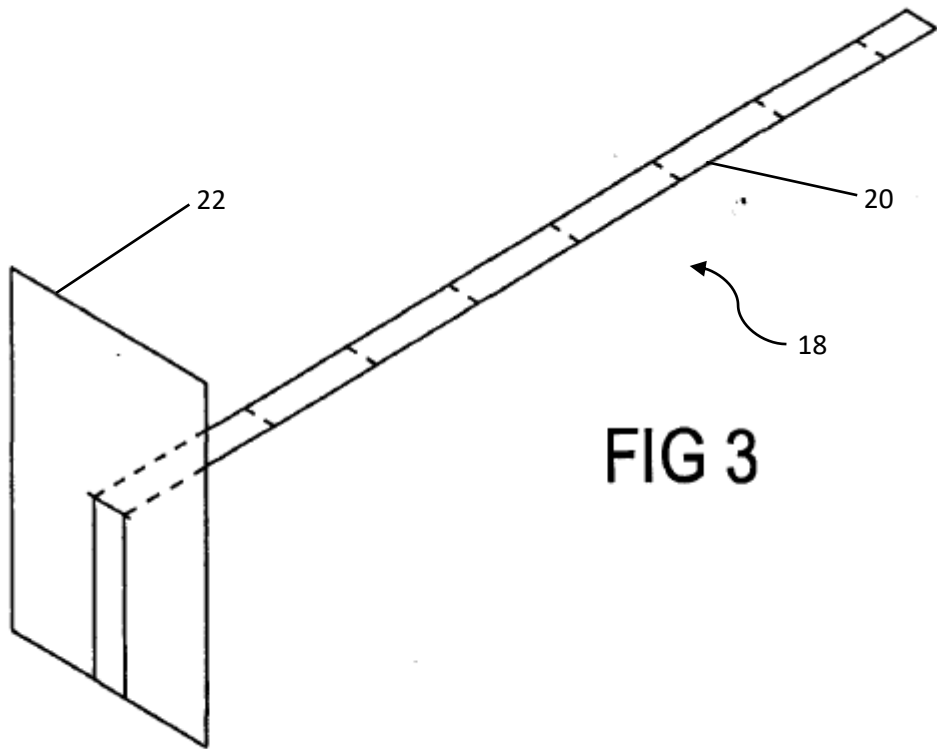
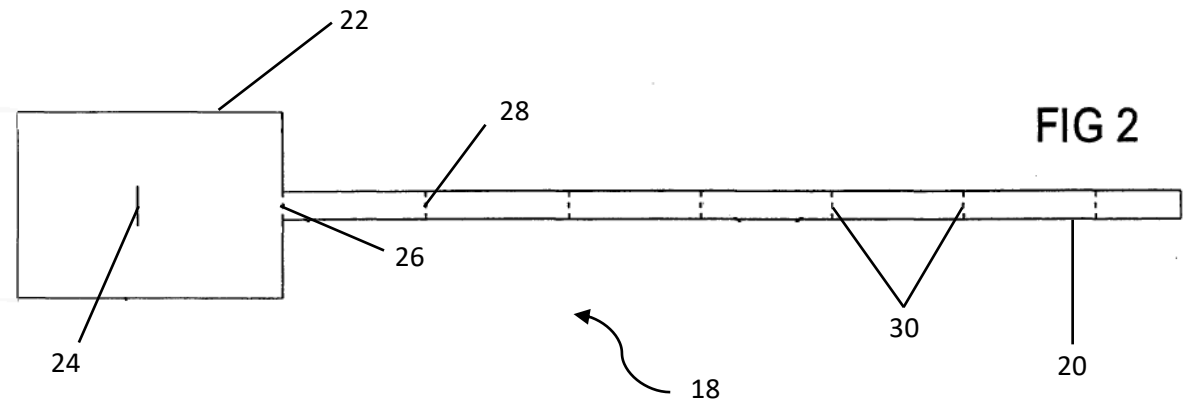

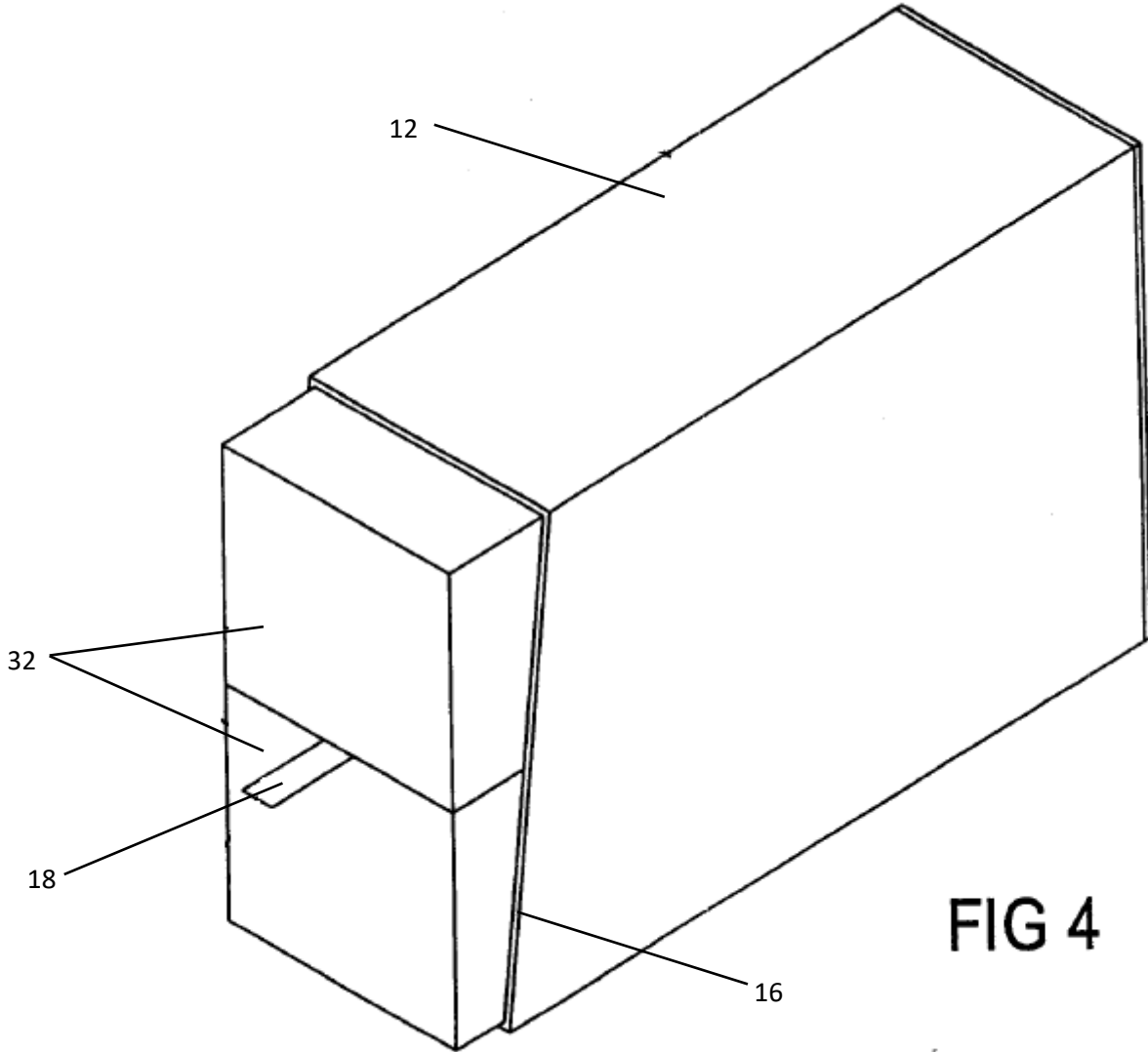

FIG 4

